

Singlehanded Series Lake Champlain YC Summer 2021

Sailing Instructions

1. Rules

The Racing Rules of Sailing for 2021-2024 Including US Sailing prescriptions and the respective class rules will apply.

2. Changes to Sailing Instructions

Any change to the sailing instructions will be notified by email and posted on the LCYC website.

<https://lcyk.info/racing/documents>

3. Schedule

First Warning will be at 1810.

The RC may change the schedule based on weather conditions or if most boats are in the starting area..

4. Racing Area

The racing area will be the waters of Shelburne Bay in the vicinity of the club.

5. Courses

The RC will designate the course with a course descriptor and a number either verbally or with placards. The course will be designated as Triangle (T), Windward-Leeward (WL) or Triangle-Windward-Leeward (TWL). If no numeral is displayed then the course is "once around". If the numeral 2 is displayed the course is "twice around". The RC may also verbally signal a WL course to the windward mark and directly back to the finish line.

6. Marks

Marks may include RED round balls, ORANGE inflatable marks and the permanent race mark "C".

7. The Start

There will be a single start sequence including all classes. The 3 minute Audible Signal Starting System described in Appendix U of the RRS as modified by Attachment A will be used. This changes Rule 26.

8. The Start line will be between an orange flag on the RC Boat and the course side of the port end starting mark. The start line will *typically* be located approximately 1/3 to 1/2 of the way up the windward leg of the course.

9. The Finish

The Finish line will be between a staff displaying an orange flag on the RC Boat and the course side of a port end round red mark. The RC boat will not move from its starting position. Finishers may or may not be given a sound signal.

10. Penalty System.

Penalties should be taken in accordance with Rule 44.1 (two-turns in all cases).

11. Protests

Protests shall be resolved by taking your penalty turns. Scofflaws will be shunned.

12. Scoring

There will be no scoring.

13. Safety Regulations

All sailors are required to have a PFD aboard while racing and strongly advised to wear a PFD at all times. A PFD shall be worn in all but drifter (<4 kt) conditions.

14. Risk Statement

RRS 3 states: 'The responsibility for a boat's decision to participate in a race or to continue to race is hers alone.' By participating in this event each competitor agrees and acknowledges that sailing is a potentially dangerous activity with inherent risks. These risks include strong winds and rough seas, sudden changes in weather, failure of equipment, boat handling errors, poor seamanship by other boats, loss of balance on an unstable platform and fatigue resulting in increased risk of injury. **Inherent in the sport of sailing is the risk of permanent, catastrophic injury or death by drowning, trauma, hypothermia or other causes.**

Attachment A – Sound Signal Starting System

Starting will follow Appendix U except as modified below.

Individual recalls shall be signalled by *sounding a single horn* and *attempting* to hail the sail number (or other distinguishing feature or skipper's name) of each OCS (On Course Side) boat. Flag X need not be displayed. This modifies Appendix U4.

General recalls shall be signalled by *sounding two horns*. This modifies Appendix U.

Start Sequence

Time until Start	Loud Horn	Description
Approx 3:35	5 short	Alert
3:00	3 long	Warning
2:00	2 long	Prep
1:30	1 long, 3 short	
1:00	1 long	
0:30	3 short	
0:20	2 short	
0:10	1 short	
0:05	1 short	
0:04	1 short	
0:03	1 short	
0:02	1 short	
0:01	1 short	
0:00	1 long	Start

Attachment B – Course Diagrams

Course T - Triangle

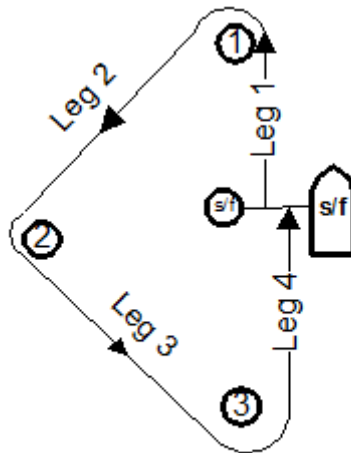

Course WL – Windward-Leeward*

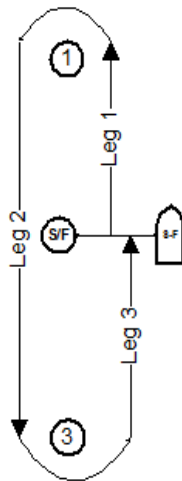

* May be modified by RC to include only a windward mark (sail to Mark 1 and return to Finish)

Course TWL – Triangle-Windward-Leeward

